

PRODUCT INFORMATION MODEL 2419 GINKO

© 2014 KURT BEIER & KATI QUINGER



Infinitely adjustable seat depth
by motorised traverse



Motorised elements
with comfort back cushion



Traverse, matt black fine structure
powder-coated







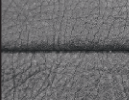
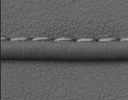
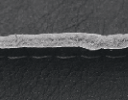

GINKO: THE MASTERPIECE - DESIGN IN TIME

A COMBINATION OF AESTHETICS, COMFORT AND FUNCTION! AN ENSEMBLE OF CREATIVE EXPRESSION AND THE VALUE OF INDIVIDUAL USE! EACH ELEMENT IS UNIQUE. THE ADJUSTABLE SEAT DEPTH ENABLES AN INDIVIDUAL SITTING OR RECLINING POSITION. THE DESIGN AND CONSTRUCTION ARE REGISTERED AS A UTILITY MODEL AS WELL AS A DESIGN PATENT. UNIQUE PIECE PRODUCTION!

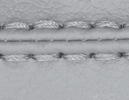

Feet: angular steel feet, black matt fine structure powder coated / Height: 16 cm / Floor distance: 7 cm
 Traverse: black matt fine structure powder coated

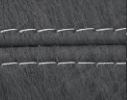
Processing options of main seam / decorative seam

	Plain seam	Lap seam	Raw edged	Moccasin seam extra charge	Twin seam extra charge	KR* (zipper piping) extra charge	Overcast seam extra charge	Piping	Two needle seam	Square seam extra charge
										
Fabric	x									
Leather	x									
Fake fur	x									

It is possible to order main seam or decorative seam either tone in tone like the colours of cover or in the contrasting colours white, nature, grey, rust and black. On request special colours possible.

*Zipper piping: optionally in the colours black, red, nature or light grey.

Wood, standard surfaces:

	Natural spruce brushed	Spruce brushed, grey stained (Vintage-Style)	Common ash natural	Ash black stained	Ash black brown	Wild oak	Beam oak	Old oak	Steamed oak	Smoked oak	American walnut
	(light puttied)		(brown puttied)			(dark puttied)	(not puttied)	(not puttied)	(dark puttied)	(dark puttied)	(dark puttied)
Price group	PG1	PG1	PG2	PG2	PG2	PG3	PG4	PG4	PG4	PG5	PG6
											
Untreated	∅	∅	*	∅	∅	*	∅	✓	∅	∅	∅
Oiled	∅	∅	*	∅	∅	✓	∅	*	∅	∅	∅
Lacquered	∅	∅	✓	✓	✓	*	∅	*	∅	∅	∅

Untreated wood gets its unique character due to the naturalness. Colour or structure variations from the samples shown are standard and have to be accepted. The wood will get a desired patina overtime with daily use, which emphasizes the character of the wood. For further care please notice the general wood information. Puttied areas may have a different colour appearance depending on the surface. For example, dark putty can look lighter on untreated wood.

* = Available on request against processing surcharge

✓ = Bullfrog recommendation and standard surface

∅ = These variants are not available



21.02.2025

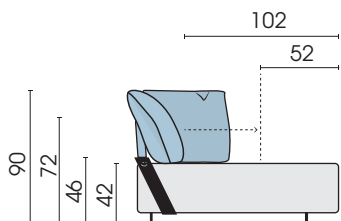

Side view (type 11M/21M/57M)

Attention! 2 motorised elements may only be combined with table T114 or stool 550 as an intermediate element. The VB1 connector set must be ordered separately for this purpose.

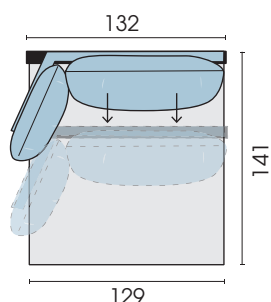

143
Element
armrest left
incl. motorised traverse
12M

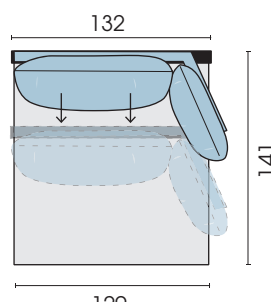

143
Element
armrest right
incl. motorised traverse
11M

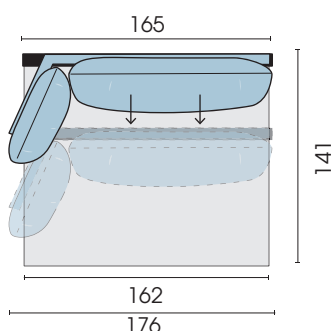

176
Sofa 2-seat
armrest left
incl. motorised traverse
22M

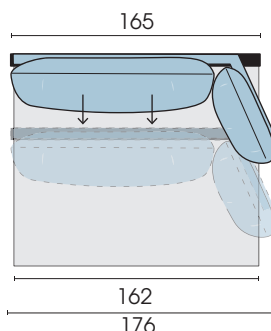

176
Sofa 2-seat
armrest right
incl. motorised traverse
21M

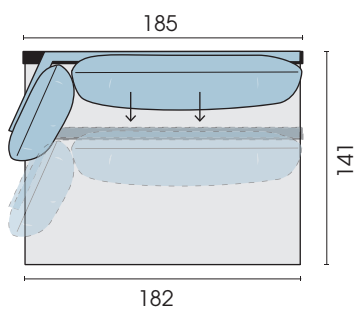

196
Sofa 2,5-seat
armrest left
incl. motorised traverse
58M

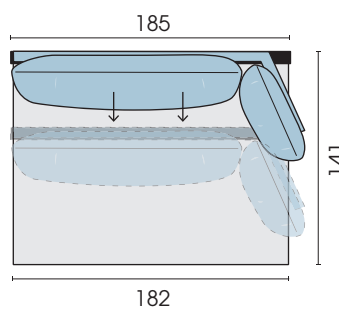

196
Sofa 2,5-seat
armrest right
incl. motorised traverse
57M

Each piece of furniture is handmade and unique. Deviations to the listed measurements may be caused by:
1. different upholstery materials (fabric, leather), 2. processing of ticking mats, 3. the pressure to combine individual parts, etc.
The seat comfort of a sofa type with larger seat depth usually differs from one with lower depth.

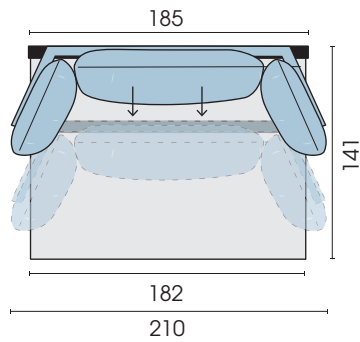

Sofa 2,5-seat
2 armrests
incl. motorised traverse
24M

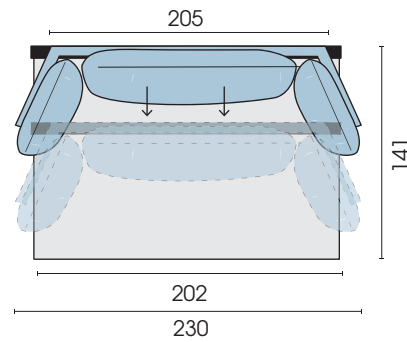

Sofa 3-Sitz
2 armrests
incl. motorised traverse
30M

Recamiere:

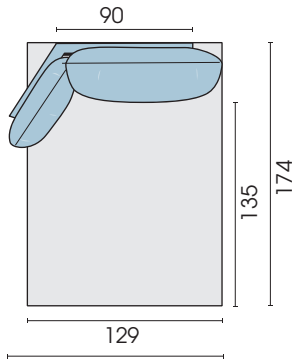

Recamiere, armrest left
420

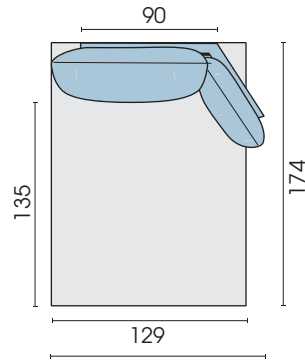

Recamiere, armrest right
410

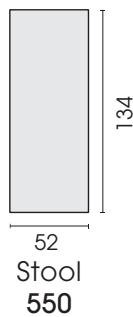

Stool
550

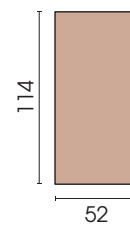
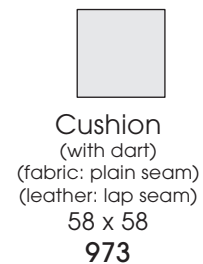
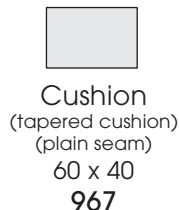
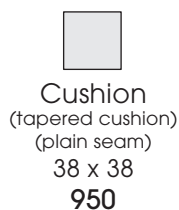

Table
height: 49
T114

Cushion:

Cushions with decorative seams are either tone in tone or contrasting colour possible.



Each piece of furniture is handmade and unique. Deviations to the listed measurements may be caused by:
1. different upholstery materials (fabric, leather), 2. processing of ticking mats, 3. the pressure to combine individual parts, etc.
The seat comfort of a sofa type with larger seat depth usually differs from one with lower depth.

Example of positioning combinations with connectors:

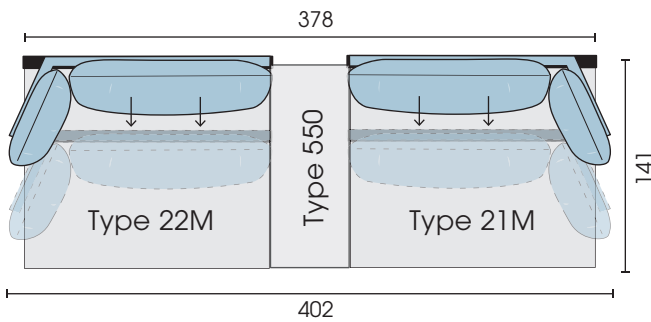

Connector set
VB1



Attention! For safety reasons (risk of jamming), two motorised movable elements may only be combined with stool type 550 or table type T114 and connectors VB1 between the sofa elements. The motorised elements are aligned using VB1 connectors, which must be ordered together with the 550 stool or T114 table.

No liability can be accepted for movable elements placed directly next to each other.

Combinations without connectors:

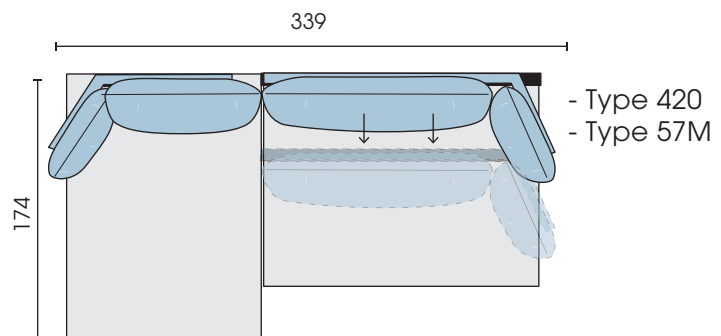
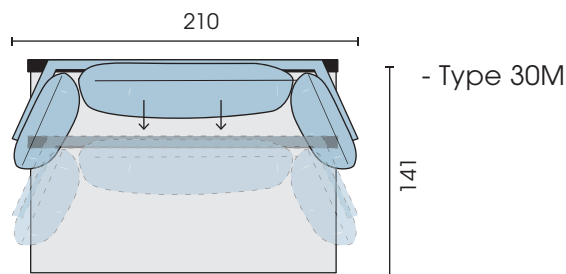

Each piece of furniture is handmade and unique. Deviations to the listed measurements may be caused by:

1. different upholstery materials (fabric, leather), 2. processing of ticking mats, 3. the pressure to combine individual parts, etc.
- The seat comfort of a sofa type with larger seat depth usually differs from one with lower depth.