

ASSEMBLY AND INSTRUCTION MANUAL

MODEL 0221 WUMMS!

© 2021 KURT BEIER & KATI QUINGER



Big sofa on a covered plateau



Luxurious with comfortable spring core



Loosely inserted seat cushions

Mounting of connectors

1. Position the elements at the place supposed to stay.

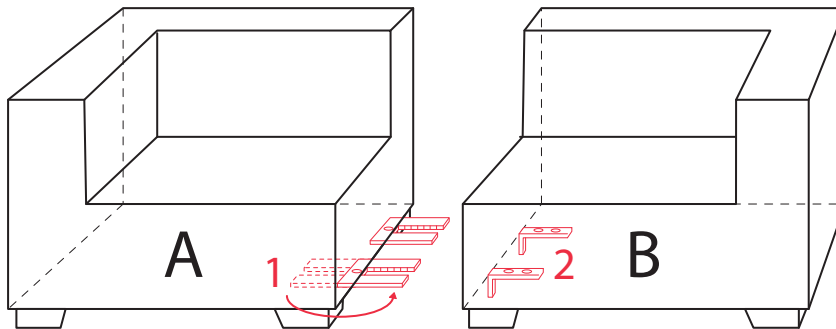

2. Turn connector ratchet 1 of element A to the outside.
3. Firmly push together part A and B, until metal guides 2 catch into guides 1.
4. In case of dismounting lift part B with the metal guides 2 and pull away.

FUNKI - how it works!

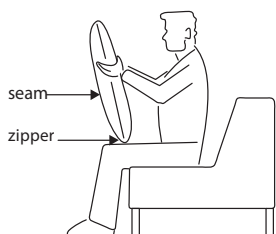

1. Take the cushion at its upper side and put the cushion on your knees with the zipper on the bottom. The seamless side faces you.

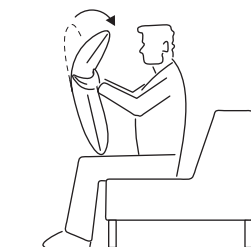

2. Move the upper part of the cushion towards yourself until the final position is reached.

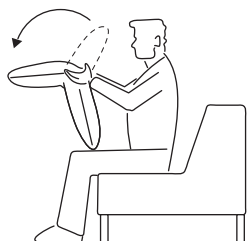

3. Now you are able to move the upper part backwards until the upper part of the cushion will click into place in the zero position.

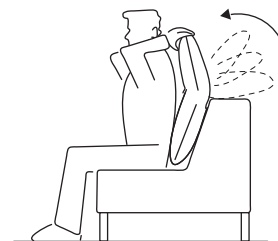

4. Now put the cushion in the preferred position (e.g. in the back, seamless side in front and zipper at the bottom). By pulling the upper part of the cushion towards yourself, you are now able to choose among 16 raster positions, however you like it.